

Combining competitions with classroom teaching to cultivate students' engineering capabilities

Gui-lin Yang

Heze University
Heze, Shandong, People's Republic of China

ABSTRACT: Students majoring in mechanical and electrical engineering, generally, have inadequate engineering capabilities. By also noting the demands of industry and employers for graduates, the necessity of cultivating students' engineering capabilities is considered and discussed in this article. Science and technology competitions, practical teaching and others aspects were considered leading to the conclusion that combining competitions with classes is the best way to cultivate a student's engineering capabilities. The results from practical experience are good. Student attendance and employment have both risen to 100%; the rate of students winning in competitions has increased by 50%; and graduates have been praised by employers.

INTRODUCTION

Engineers tend to have been students at application-oriented universities. The main work of engineers is to plan, design, implement, operate and manage projects. They have a crucial influence on the development of enterprises and have been vividly described as *the first productive (element) of enterprises*. Mechanical engineering involves the design and production of machinery for industry. The quality of the training for mechanical engineers is directly related to the quality of the machinery produced. Therefore, training has an important role in revitalising industrial machinery and improving China's international competitiveness.

In recent years, although the number of undergraduates majoring in mechanical engineering has increased greatly, mechanical engineers with strong abilities in research, development, design, planning and innovation are very scarce, though they are needed urgently by society. Especially scarce is service and management talent on the front line of production that can complete the tasks from design to production. For a long period of time in China, the vast majority of mechanical engineering graduates have gone directly on to the production line as engineers. The employment situation for electromechanical graduates of Heze University confirms this.

Engineering education should be based in local application-oriented universities. The focus of the training should be to produce applied engineers and other professionals with engineering capabilities suitable for the practical work required by their first job position.

The reform of higher education should promote quality as the first priority, whether now or in the future [1]. In recent years, the Ministry of Education, the provincial department of education, science and technology associations, and others have organised various forms of competitions, especially electronic competitions. Their aim is to promote education reform and to encourage students to be creative, develop practical ability and cultivate a student's personality so that each one achieves more in higher engineering education.

CAUSES OF STUDENTS MAJORING IN MECHANICAL AND ELECTRICAL ENGINEERING HAVING LOW ENGINEERING CAPABILITIES

At the present stage, the education in most engineering colleges belongs to *the former engineering education stage*, i.e. it is focused only on teach students basic science and engineering knowledge, and neglecting the cultivation of their engineering capabilities. As a result, graduates are only *semi-finished products*. The main causes of students majoring in mechanical and electrical engineering having low engineering capabilities are as follows:

- Knowledge is narrow. It is often said that students understand machines but not power, which is a common problem for them majoring in mechanical engineering. This means students are not fully qualified to work after graduation. Their computer software abilities need to be further improved. In addition, a qualified mechanical engineer should understand economy and management, should be conscious of project quality and should understand the engineering concept of *environment-people-society-technology*.
- Awareness of engineering is defective. Teaching content has no validation links to confirm the content is *right*. Some teachers are not strict with the quality of designs - which makes students regard rigorous engineering design as a trifling matter and, hence, faulty designs are produced.
- Problem-solving ability is weak. Students are used to being *fed* all they need for learning. They are inadequate at practical work with their hands and lack the ability to solve problems. If something is missing they do not know what to do. Practical projects involving setting up platforms are very rare.
- University teaching is poor. There are many problems in teaching. Some teachers are careless and do not pay enough attention to teaching, resulting in a severely fragmented education. Lessons may be inadequately prepared and are monotonous. Some teachers neglect the roles of students in class and, thus, seriously weaken the enthusiasm of students. Some teachers focus on teaching theoretical knowledge particularly related to the key points in examinations and ignore the importance of the combination of theory and practice. Such teaching is not conducive to students mastering knowledge systematically and does not develop a student's innovative ability.

COMBINING COMPETITIONS WITH CLASSES CONVERTS A CLASS INTO A FACTORY

Combining competitions with classes cultivates students' engineering capabilities:

Competitions can test a student's quality, capabilities and more [2]. However, through participating in many national undergraduate electronic design competitions, robot contests, and electromechanical innovation competitions, the author has found that students cannot well put theory into practice. They do not know how to proceed when they meet typical problems. At the same time, this exposes the drawbacks of paying more attention to theory and neglecting practice in teaching. Therefore, it is necessary to reform and improve the relevant curricula so that college students can better meet the needs of the community.

Reflecting the needs of competitions, the curriculum for electrical and mechanical engineering at Heze University has been improved and enriched. There is new course material and the syllabus and examinations have been updated. In teaching, outdated content has been removed and advanced, and cutting-edge content introduced. There is increased use of simulation software, as well as more practical applications. The new teaching system is shown in Figure 1. It aims to enrich classroom teaching and stimulate student interest in learning and, hence, improve their engineering capabilities.

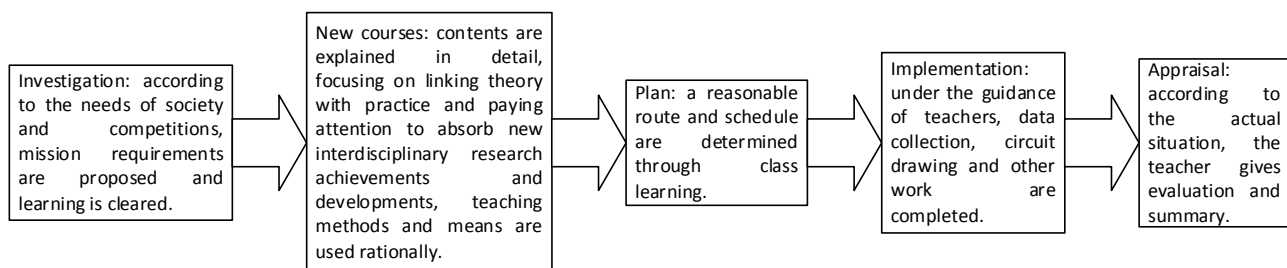

Figure 1: A new type of teaching system.

Combining competitions with classes provides a huge incentive and encouragement for students:

Currently, there are many domestic competitions, e.g. the Challenge Cup, Electronic Design Competition and the Mechanical Innovation Design Competition. Competitions led by the Ministry of Education have a great influence in China. The cultivation of students' engineering capabilities not only requires engineering theory, but also the accumulation of practical engineering experience. Combining competitions with classes is less than a year old at Heze University but already has had a big, positive impact on cultivating students' engineering capabilities.

Careful preparation is required to introduce content and technology relevant to competitions into classroom teaching.:

Although practical teaching can enable students to deepen their understanding and mastery of theory, it can also play an important role in cultivating a student's practical ability, creativity and analytical ability to solve problems. There are still many inadequacies, such as poor equipment [3]. Because of this, at Heze University, the practical teaching has been reformed. There are more scalable, design and innovative experiments. For example, using the C topic of the 2011 National Undergraduate Electronic Design Competition and the D topic of the 2012 National Undergraduate Electronic Design Competition as bases, a multi-car experiment has been introduced. Students have designed, built and commissioned a universal motor drive circuit [4], as shown in Figure 2. They have mastered the design and wireless transmission as part of the 2013 National Undergraduate Electronic Design Contest.

At the University, laboratories have been expanded, new equipment has been purchased, open laboratories have been constructed, and full use has been made of the school and businesses to jointly develop students' engineering capabilities.

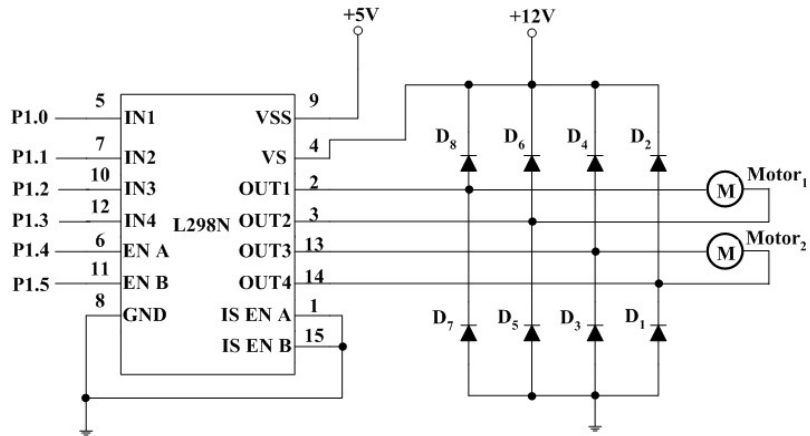

Figure 2: The driving circuit of the universal motor.

Combining competitions with classes enhances students' awareness of engineering, professional ethics and increases their self-confidence:

Teachers have pulled relevant competition content into classroom teaching, which has improved their professional standing, and increased students' knowledge. Simulations and the construction of engineering environments improve students' engineering skills, as well as their self-motivation and self-confidence. Group collaboration and discussion in teams encourages problem-solving and provides a solid foundation for students' life as engineers. Through the application of theoretical knowledge to practice, the ability of students to integrate theory with practice has been further enhanced. The personal experience of the author is that students' ability in applying knowledge, basic skills, problem-analysis and problem-solving abilities have been greatly improved.

IMPROVING STUDENT'S ENGINEERING CAPABILITIES

Develop double-profession teachers:

Teachers play a very important role in the education. High quality teachers can enable students to develop, while low quality teachers cause students to decline. Various measures have been taken at the University, so that teachers are encouraged to acquire new knowledge and absorb new results. Teachers can use innovative teaching methods to enrich students' knowledge and abilities. Thus, teachers can become enlighteners, mentors and career planners for students.

Make the contents of class teaching closer to engineering practice:

The effective and rational organisation of class teaching plays a very important role in improving the quality of teaching and cultivating a student's engineering capabilities. Teachers should do adequate preparation for class teaching, including a deep analysis of textbooks and refer to other relevant information while taking account of the level of the students. Practical and class teaching should be integrated. Teachers should carefully assess the breadth and depth of the teaching content.

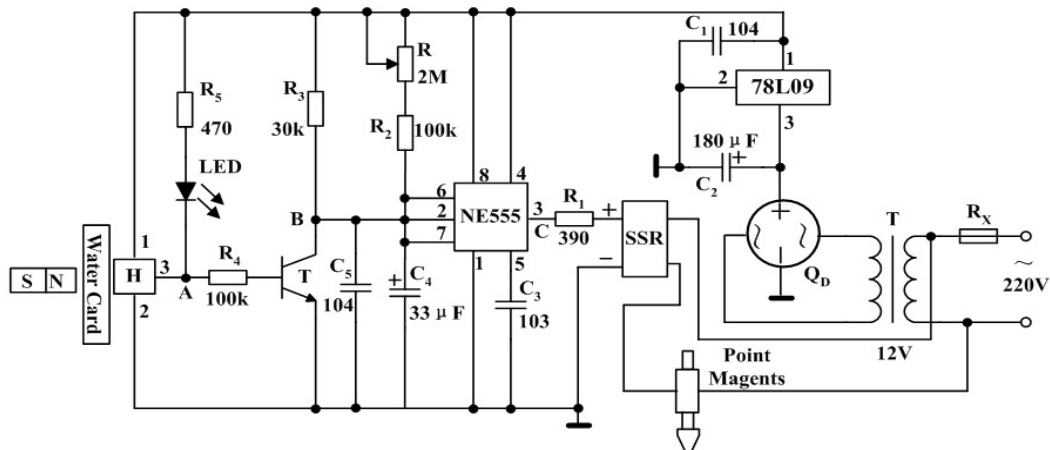

Figure 3: The intelligent device of supplying water based on a water card.

Technological advances, new ideas and new methods reflected in competitions should be absorbed into class teaching to enable students to further expand their horizons and practical ability. For example, in teaching applications of the Hall sensor, the 555 timer (a standard integrated circuit), switches and transistors can be used by students to design an intelligent water supply device based on a water card; the circuit is shown in Figure 3. The mono-stable circuit consists of the 555 timer and its peripheral circuits [4]. The adjustable potentiometer R can be used to avoid forgetting to unplug the water card and so avoid waste. The steady state time of the monostable circuit is given by the following equation:

$$T = 1.1C_4(R_1 + R_2) \quad (1)$$

where R_1 is the resistance of the potentiometer.

Typical values of the output voltage U_A of the Hall sensor, the collector voltage U_B of the transistor and the output voltage U_C of the 555 timer were produced in several tests; part of the results are shown in Table 1.

Table 1: A selection of the measured voltages.

Status of the water card	No.	U_A (V)	U_B (V)	U_C (V)
Absence of water card	1	0.12	8.70	0.12
	2	0.13	8.60	0.11
	3	0.10	8.90	0.13
	4	0.12	8.47	0.11
Presence of water card	1	4.10	0.27	8.27
	2	3.82	0.21	8.31
	3	3.97	0.24	8.46
	4	4.06	0.19	8.32

The measured results show that theoretical analysis coincides with the measured values and that the circuit is suitable for practical application [5].

Guide students to be practically oriented:

That education should be people-oriented and student-centred is a very important part of modern study. In class, students should become true masters and their interest in learning directly determines the quality of learning [6]. Therefore, it is necessary to inspire their interest in learning. Modern educational philosophy emphasises the enthusiasm of students to actively participate in learning and that students have a great learning potential. If students have an opportunity to display their knowledge, their enthusiasm for learning will be improved and their thinking will become more active. Opportunities should be created for students to show their abilities, which lays a solid foundation for their all-round development. Students need to be considered individually to cultivate their innovative and application capabilities.

The expected effect on students' engineering capabilities:

Content related to competitions has been integrated into the teaching and has obviously improved the quality of teaching compared with the traditional pattern of teaching and, in fact, has achieved remarkable results. Student interest has been stimulated, the self-confidence of students has been enhanced and there is a more active atmosphere in class. The practical ability of students has been significantly improved and test scores and employment rates have improved year by year. Innovation and team co-operation also have gradually increased. Striking results have been achieved in competitions. Indicative data are shown in Table 2.

Table 2: Indicative data.

Time (Year)	Student's attendance %	National first prize %	The rate of employment %	Opinions of employers
2004–2005	80	0	90	good
2005–2006	65	0	82	medium
2007–2008	95	3	95	good
2008–2009	98	5	100	excellent
2010–2011	100	12	100	excellent
2012–2013	100	26	100	excellent

CONCLUSIONS

Since 2007, the Department of Electromechanical Engineering at Heze University has included in classes the teaching content related to competitions and the results have been good. In various competitions, 46 national first prizes have been won, with more national second prizes and a number of other awards in Shandong Province. Students have greatly improved in analysis and problem-solving, innovation, co-operation and in other areas. Graduates have been praised by teachers and employers. Introducing competitions, the application knowledge related to competitions and the cutting-edge technology related to competition into class teaching has played an invaluable role in cultivating students' engineering capabilities.

Practice has proved that the incorporation of competition into teaching has improved and deepened the development of innovative practices in university education. In turn, the development of innovative practices has improved students' engineering capabilities, which have also improved performance in various competitions. Competition is an opportunity to encourage reasonable teaching reforms. By constantly learning from experience, more and better talent can be cultivated for the country.

REFERENCES

1. Yang, S. and Wang, J., To really grasp the quality of class teaching. *China Higher Educ. Research*, 7, 4, 1-3 (2007).
2. Chen, R. and Yu, C., Discussion on the electronic designing competition to college students' comprehensive ability raise. *J. of Jiangxi Institute of Educ.*, 28, 3, 60-62 (2007).
3. Li, Y., Starting electronic design contest enhancing practical teaching reform. *China Modern Educational Equipment*, 8, 7, 131-133 (2010).
4. Mengchang Y., *The Basic and Concise Course of Digital Electronic Technology*. Beijing: Higher Education Press, 407-409 (2011).
5. Liang, T., Rao, W. and Zhengjin, H., *Integrated Electronic Design and Practice*. Nanjing: Southeast University Press, 30-34, 174-175 (2011).
6. Gao, H., Promote students' principal role in class to improve teaching efficiency. *The Science Educ. Article Collects*, 7, 12, 112-113 (2011).